

**BLADEZ**<sup>®</sup>  
F I T N E S S S

# R250



## OWNER'S MANUAL

*Important: Read all instructions carefully before using this product. Retain this owner's manual for future reference.*

Bladez Fitness | 20155 Ellipse, Foothill Ranch, California 92610 | p.949.206.0330 | f.949.206.0013 | [www.BladezFitness.com](http://www.BladezFitness.com)

# BLADEZ<sup>®</sup>

F I T N E S S

## TABLE OF CONTENTS

Title	Page
Introduction	03
Warnings and Labels	04
Safety Information	05
Exercise Instruction	06
Training Guidelines	07
Suggested Stretching	11
Assembly Instructions	13
Console Operations	23
Maintenance and Cleaning	32
Exploded View Drawing	33
Parts List	35
Warranty	36

## CONGRATULATIONS

Congratulations on your purchase of Bladez Fitness equipment. We hope you appreciate the style, quality, and value that exercisers around the world have come to expect from Bladez Fitness.

If you have any questions, concerns or product issues please call our Customer Service Team at 1-866-325-2339 or email us at [CustomerSupport@BHNorthAmerica.com](mailto:CustomerSupport@BHNorthAmerica.com).

Carefully read through the instructions contained in this manual. They provide you with important information about assembly, safety, fitness and use of the machine. Please read ALL the safety information contained on the following page.

# WARNINGS AND LABELS

## ⚠️ WARNING ⚠️ AVERTISSEMENT

This device complies with Part 15 of the FCC Rules. Operation is subject to the following two conditions: (1) This device may not cause harmful interference, and (2) this device must accept any interference received, including interference that may cause undesired operation.

Cet appareil conforme avec Article 15 des règlements de FCC. Le fonctionnement est soumis au 2 conditions suivantes: (1) Cet appareil ne peut pas causer des interférences nuisible, et (2) cet appareil doit accepter toutes les interférence reçues, y compris les interférences qui peuvent causer l'opération indésirable.

## ⚠️ WARNING ⚠️ AVERTISSEMENT

- Misuse of this machine may result in serious injury.
- Read user's manual prior to use and follow all warnings and instructions.
- Do not allow children on or around machine.
- User weight must not exceed 275 lbs/125 kgs.
- This products should always be used on a level surface.
- This product is not intended for therapeutic use.
- Replace label if damaged, illegible or removed.
- Keep body and clothing free and clear of all moving parts.
- The heart rate displayed may be inaccurate and should be used for reference only.
- Consult a physician prior to using any exercise equipment.
- This bike does not free-wheel. Pedals continue to spin when you stop pedaling.
- Spinning pedals can cause injury.
- Reduce pedal speed in a controlled manner.
- La mauvaise utilisation de cet appareil peut entraîner des blessures graves.
- Lisez le manuel de l'utilisateur avant utilisation et suivez tous les avertissements et les instructions.
- Ne permettez pas aux enfants de se tenir sur ou autour de l'appareil.
- Le poids de l'utilisateur ne devrait pas excéder 125.
- Cet appareil doit toujours être utilisé sur une surface plane.
- Ne pas faire usage à des fins thérapeutiques.
- Remplacez l'autocollant s'il est endommagé, illisible ou manquant.
- Gardez le corps et les vêtements, libre et éloigner de toutes les pièces mobiles.
- La fréquence cardiaque démontré peut être inexacte et doit être utilisé à titre de référence seulement.
- Consulter un médecin avant d'utiliser tout équipement d'exercice.
- Ce vélo n'est pas roue libre. Les pédales continue à tourner lorsque vous arrêtez de pédaler.
- Les pédales qui roules peuvent causer des blessures.
- Réduisez la vitesse des pédales sous une manière contrôlable.

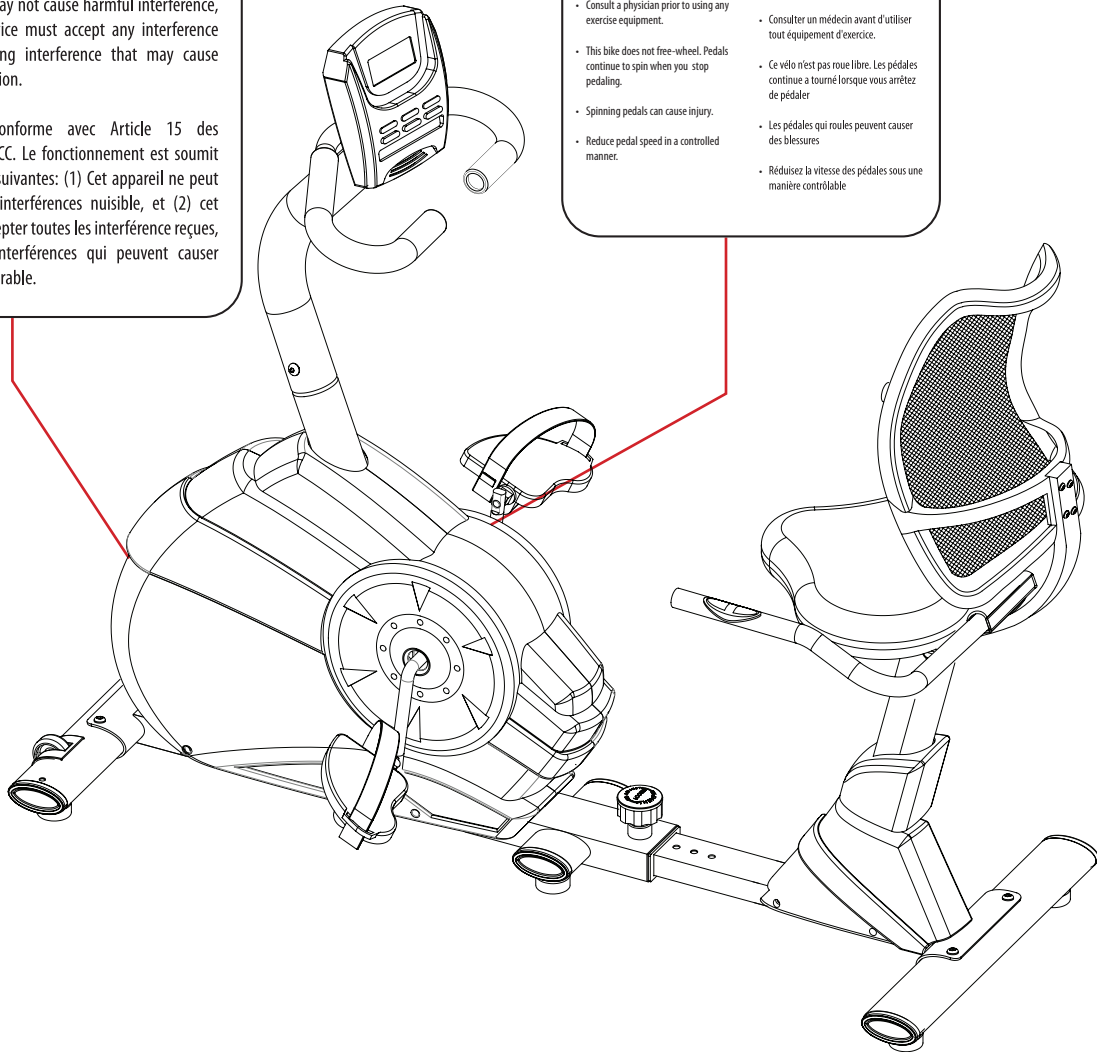

# SAFETY INFORMATION

## PRECAUTIONS

This recumbent bike has been designed and constructed to provide maximum safety. Nevertheless, certain precautions should be taken when using exercise equipment. Read the whole manual before assembling and using the machine. Please observe the following safety precautions:

1. Keep children and pets away from this equipment at all times. DO NOT leave them unsupervised in the room where the machine is kept.
2. If you experience dizziness, nausea, chest pains or any other symptom while using this machine STOP the exercise. SEEK IMMEDIATE MEDICAL ATTENTION!
3. Use the machine on a level and solid surface. Adjust the feet for stability.
4. Keep your hands away from any of the joints and moving parts.
5. Wear clothing suitable for doing exercise. Do not wear baggy clothing that might get caught in the machine. Always wear athletic shoes when using the machine and tie the laces securely.
6. This machine must only be used for the purposes described in this manual. DO NOT use accessories that are not recommended by Bladez Fitness. Read manual prior to use and follow all warnings and instructions.
7. Do not place sharp objects near the machine.
8. Any person with physical or coordination limitations should not use the machine without the assistance of a qualified person or doctor. Misuse of this machine may result in serious injury.
9. Do warm-up stretching exercises before using the equipment.
10. Do not use the machine if it is not working correctly.
11. Before using the machine, thoroughly inspect the equipment for proper assembly.
12. Keep a perimeter of 3 feet (1 meter) around the machine before operating the equipment.
13. Use only authorized and trained technicians if a repair is needed.
14. Please follow the advice for correct training, as detailed in the Training Guidelines.
15. Use only the tools provided to assemble this machine.
16. Replace warning labels if damaged, illegible or removed.
17. This machine was designed for a maximum user weight of 275 lbs (125 kgs)
18. The machine can only be used by one person at a time.
19. The exercise bicycle is for consumer use only.

**Caution:** Consult your doctor before beginning to use the machine or any exercise program. Read all of the instructions before using any exercise equipment.

KEEP THESE INSTRUCTIONS SAFE FOR FUTURE USE.

**BLADEZ**  
FITNESS

## EXERCISE INSTRUCTION

Use of the machine offers various benefits; it can improve fitness, muscle tone and when used in conjunction with a calorie controlled diet, it can help you lose weight.

1. Consult your doctor before starting any exercise program. It is advisable to undergo a complete physical examination.
2. Work at the recommended exercise level. Do not over exert yourself.
3. If you feel any pain or discomfort, stop exercising immediately and consult your doctor.
4. Wear appropriate clothing and footwear for the exercise; do not wear loose clothing; do not wear leather soled shoes or footwear with high heels.
5. It is advised that you do warm-up stretches before working out.
6. Get on the equipment slowly and securely.
7. Select the program or workout option that is most closely aligned with your workout interests.
8. Start slowly and work your way up to a comfortable pace.
9. Be sure to cool down after your workout.

## TRAINING GUIDELINES

Exercise is one of the most important factors in the overall health of an individual. Listed among its benefits are:

- Increased capacity for physical work (strength endurance)
- Increased cardiovascular (heart and arteries/veins) and respiratory efficiency
- Decreased risk of coronary heart disease
- Changes in body metabolism, e.g. losing weight
- Delaying the physiological effects of age
- Reduction in stress, increase in self-confidence, etc.

There are several components of physical fitness and each is defined below.

### *STRENGTH*

The capacity of a muscle to exert a force against resistance. Strength contributes to power and speed.

### *MUSCULAR ENDURANCE*

The capacity to exert a force repeatedly over a period of time, e.g. it is the muscular endurance of your legs to carry you 10 km without stopping.

### *FLEXIBILITY*

The range of motion of your joints. Improving flexibility involves the stretching of muscles and tendons to maintain or increase suppleness, and it provides increased resistance to muscle injury or soreness.

### *CARDIO-RESPIRATORY ENDURANCE*

The most essential component of physical fitness. It is the efficient functioning of the heart and lungs.

### *AEROBIC FITNESS*

Is an exercise of relatively low intensity and long duration, which depends primarily on the aerobic energy system. Aerobic means "with oxygen", and refers to the use of oxygen in the body's metabolic or energy-generating process. Many types of exercise are aerobic, and by definition are performed at moderate levels of intensity for extended periods of time.

### *ANAEROBIC TRAINING*

Is an exercise intense enough to trigger anaerobic metabolism. This means "without oxygen" and is the output of energy when the oxygen supply is insufficient to meet the body's long term energy demands. (For example, a 100 meter sprint.)

### *OXYGEN UPTAKE*

The effort that you can exert over a prolonged period of time is limited by your ability to deliver oxygen to the working muscles. Regular vigorous exercise produces a training effect that can increase your aerobic capacity by as much as 20 to 30%. An increased VO<sub>2</sub> Max indicates an increased ability of the heart to pump blood, of the lungs to ventilate oxygen, and of the muscles to take up oxygen.

### *THE TRAINING THRESHOLD*

This is the minimum level of exercise which is required to produce significant improvements in any physical fitness parameter.

### *OVERLOAD*

This is where you exercise above your comfort level. The intensity, duration and frequency of exercise should be above the training threshold and should be gradually increased as the body adapts to the increasing demands. As your fitness level improves, the training threshold should rise. Working through your program and gradually increasing the overload factor is important.

### *PROGRESSION*

As you become more fit, a higher intensity of exercise is required to create an overload and therefore provide continued improvement.

### *SPECIFICS*

Different forms of exercise produce different results. The type of exercise that is carried out is specific to the muscle groups being used and to the energy source involved. There is little transfer of the effects of exercise, i.e. from strength training to cardiovascular fitness. That is why it is important to have an exercise program tailored to your specific needs.

### *REVERSIBILITY*

If you stop exercising or do not do your program often enough, you will lose the benefits you have gained. Regular workouts are the key to success.

### *WARM-UP*

Every exercise program should start with a warm-up where the body is prepared for the effort to come. It should be gentle and preferably use the muscles group to be involved later. Stretching should be included in both your warm-up and cool down, and should be performed after 3-5 minutes of low intensity aerobic activity or calisthenic type exercise.

### *WARM DOWN OR COOL DOWN*

This involves a gradual decrease in the intensity of the exercise session. Following exercise, a large supply of blood remains in the working muscles. If it is not returned promptly to the central circulation, pooling of blood may occur in the muscles.



### *HEART RATE*

As you exercise, your heart beat increases. This is often used as a measure of the required intensity of an exercise. You need to exercise hard enough to condition your circulatory system, and increase your pulse rate, but not enough to strain your heart.

Your initial level of fitness is important when developing an exercise program for you. When starting, you can get a good training effect with a heart rate of 110-120 beats per minute (BPM). If you are more fit, you will need a higher threshold of stimulation.

To begin with, you should exercise at a level that elevates your heart rate to about 65 to 70% of your maximum. If you find this is too easy, you may want to increase it, but it is better to lean on the conservative side.

As a rule of thumb, the maximum heart rate is 220 minus your age. As you increase in age, your heart, like other muscles, loses some of its efficiency. Some of its natural loss is won back as fitness improves. The following table is a guide to those who are “starting fitness.”

Age Target Heart Rate	25	30	35	40	45	50	55	60	65
10 Second Count	23	22	22	21	20	19	19	18	18
Beats per Minute	138	132	132	126	120	114	114	108	108

### *PULSE COUNT*

The pulse count (on your wrist or carotid artery in the neck, taken with two index fingers) is done for ten seconds, taken a few seconds after you stop exercising. This is for two reasons: (a) 10 seconds is long enough for accuracy, (b) the pulse count is to approximate your BPM rate at the time you are exercising. Since heart rate slows as you recover, a longer count isn't as accurate.

The target is not a magic number, but a general guide. If you're above average with your fitness, you may work comfortably a little above that suggested for your age group. The following table is a guide.

Age Target Heart Rate	25	30	35	40	45	50	55	60	65
10 Second Count	26	26	25	24	23	22	22	21	20
Beats per Minute	156	156	150	144	138	132	132	126	120

Don't push yourself too hard to reach the figures on this table. It can be very uncomfortable if you over exercise. Let it happen naturally as you work through your program. Remember, the target is a guide, not a rule, a little above or below is just fine.

Two final comments: (1) don't be concerned with day to day variations in your pulse rate, being under pressure or not enough sleep can affect it; (2) your pulse rate is a guide, don't become a slave to it.

### *MUSCLE SORENESS*

For the first week or so, muscle soreness may be the only indication you have that you are on an exercise program. This, of course, does depend on your overall fitness level. A confirmation that you are on the correct program is a very slight soreness in most major muscle groups. This is quite normal and will disappear in a matter of days.

If you experience major discomfort, you may be on a program that is too advanced, or you have increased your program too rapidly.

If you experience PAIN during or after exercise, your body is telling you something. Stop exercising and consult your doctor.

### *WHAT TO WEAR*

Wear clothing that will not restrict your movement in any way while exercising. Clothes should be light enough to allow the body to cool. Excessive clothing that causes you to perspire more than you normally would gives you no advantage. The extra weight you lose is body fluid and will be replaced with the next glass of water you drink. Always wear a pair of athletic shoes.

### *BREATHING DURING EXERCISE*

Do not hold your breath while exercising. Breathe normally as much as possible. Remember, breathing involves the intake and distribution of oxygen, which feeds the working muscles.

### *REST PERIODS*

Once you start your exercise program, you should continue through to the end. Do not break off halfway through and then restart at the same place later on without going through the warm-up stage again. The rest period required between exercises may vary from person to person.

## SUGGESTED STRETCHES

### *Head Rolls*

Rotate your head to the right for one count while feeling the stretch up the left side of your neck. Next, rotate your head back for one count, stretching your chin to the ceiling. Rotate your head to the left for one count, and finally, drop your head to your chest for one count.

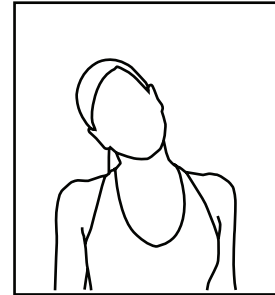

### *Shoulder Lifts*

Lift your left shoulder up toward your ear for one count. Then lift your right shoulder up for one count as you lower your left shoulder.

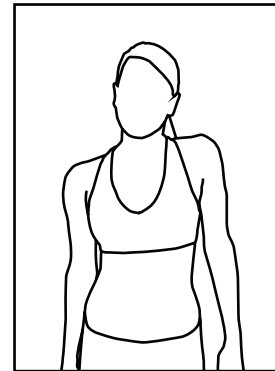

### *Side Stretches*

Open your arms to the side and continue lifting them until they are over your head. Reach your left arm as far upward as you can for one count. Feel the stretch up your left side. Repeat this action with your right arm.

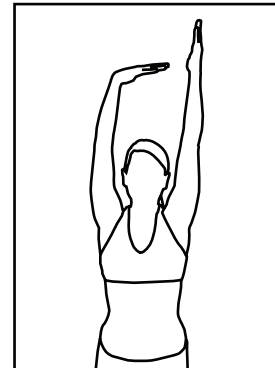

### *Quadriceps Stretch*

With one hand against a wall for balance, reach behind you and pull your left foot up. Bring your heel as close to your buttocks as possible. Hold for 15 counts and repeat with right foot up.

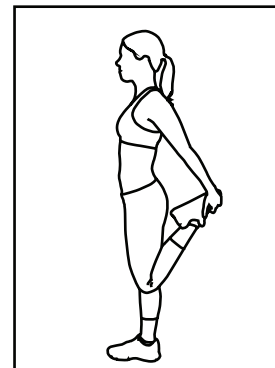

## SUGGESTED STRETCHES

### *Inner Thigh Stretch*

Sit with the soles of your feet together with your knees pointing outward. Pull your feet as close into your groin as possible. Gently push your knees towards the floor. Hold for 15 counts.

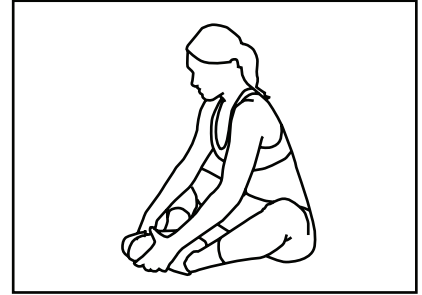

### *Toe Touches*

Slowly bend forward from your waist, letting your back and shoulders relax as you stretch toward your toes. Reach down as far as you can and hold for 15 counts.

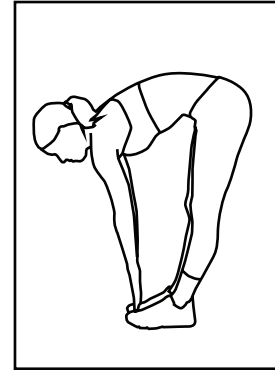

### *Hamstring Stretches*

Sit with your right leg extended. Rest the soles of your left foot against your right inner thigh. Stretch toward your toes as far as possible. Hold for 15 counts. Relax and then repeat with left leg extended.

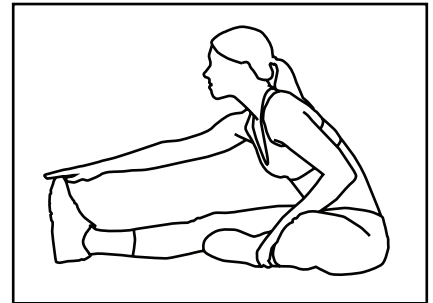

### *Calf/Achilles Stretches*

Lean against a wall with your right leg in front of the left and your arms forward. Keep your left leg straight and the right foot on the floor; then bend the right leg and lean forward by moving your hip toward the wall. Hold, then repeat on the other side for 15 counts.

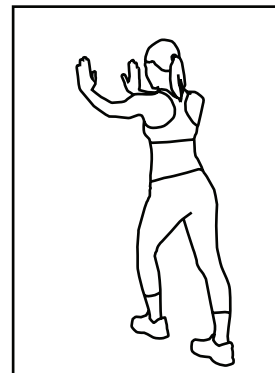

# ASSEMBLY INSTRUCTIONS

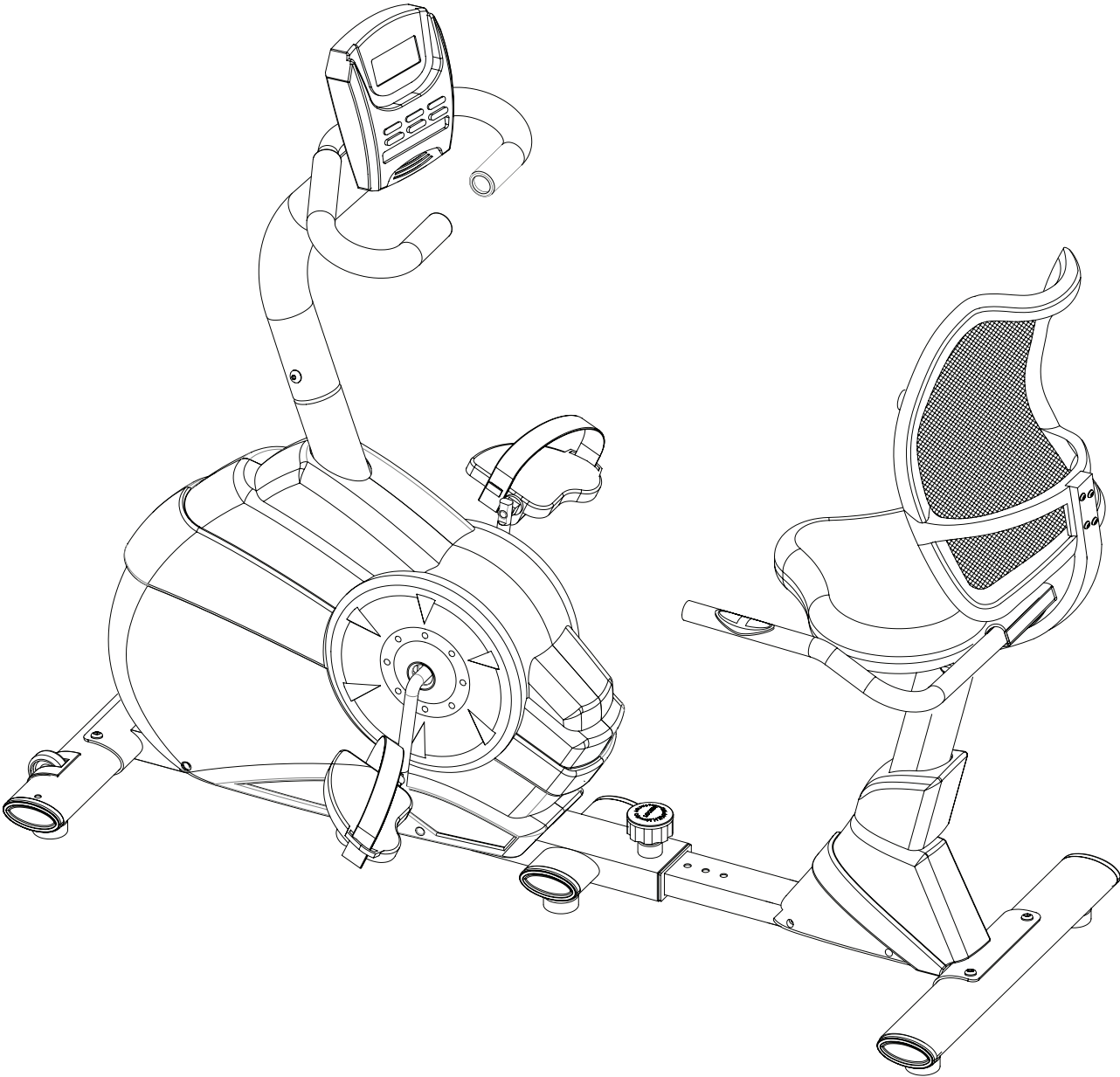

## STEP 1

Thread Foot Pads (18) on the front Bottom Tube (19).

Attach the front Bottom Tube (19) to the Main Frame (1) with Screw (46) and Washer (50).

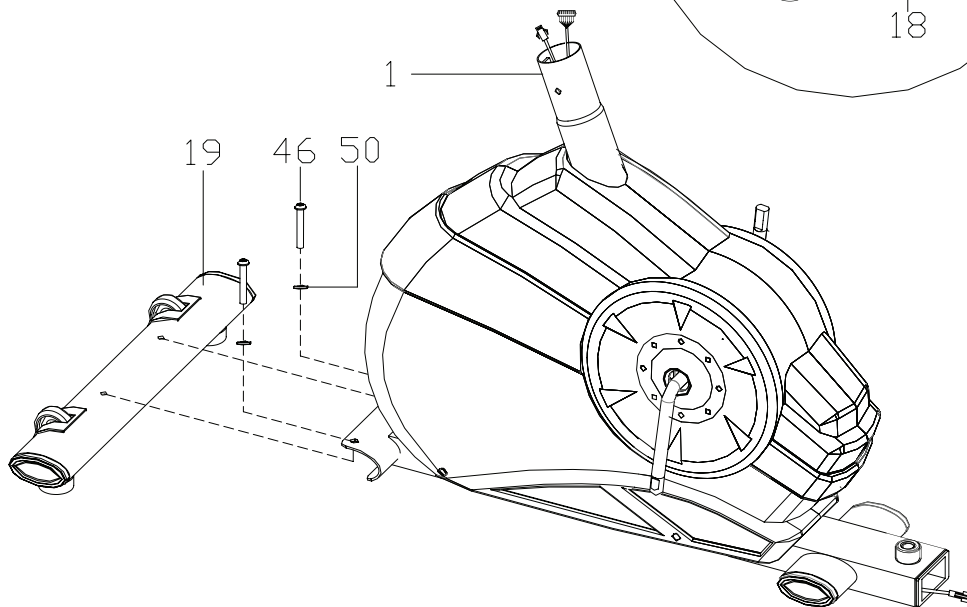
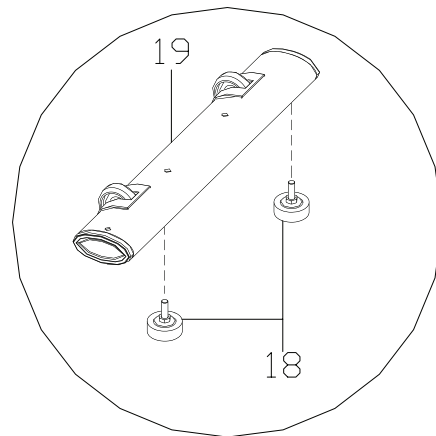
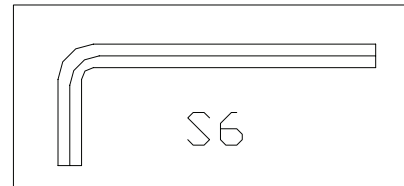
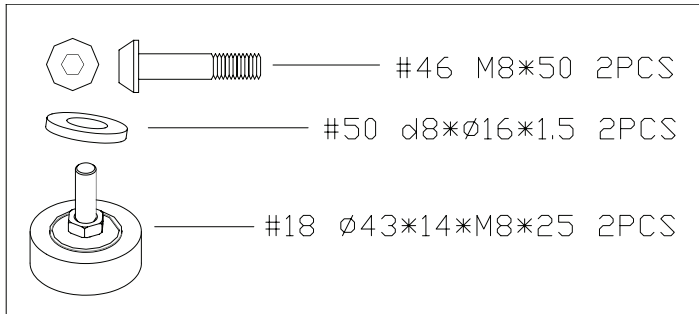

## STEP 2

Thread Foot Pads (18) on the Main Frame (1).

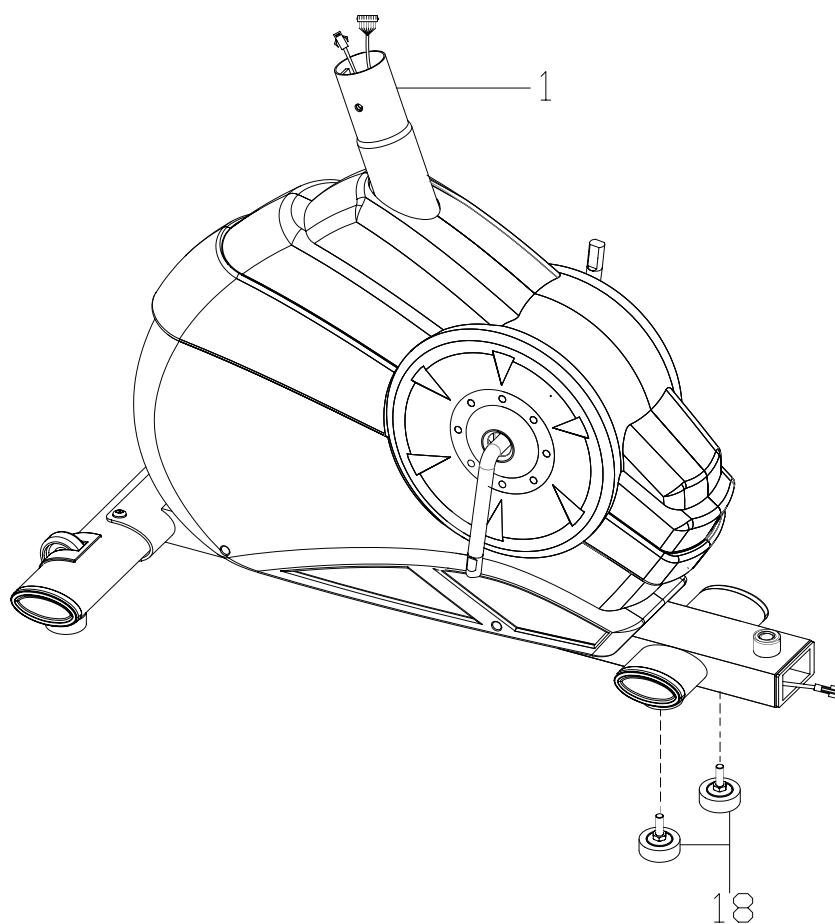
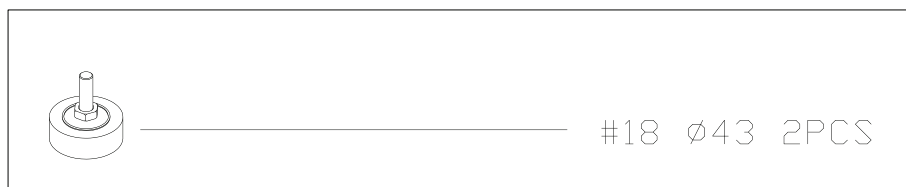

### STEP 3

Thread Foot Pads (18) on the back Bottom Tube (30).

Attach the back Bottom Tube (30) to the extension Tube Joint (29) with Screw (46) and Washer (50). Connect Wire (9) and (26) put extension Tube Joint (29) into Main Frame (1) lock with Knob (49).

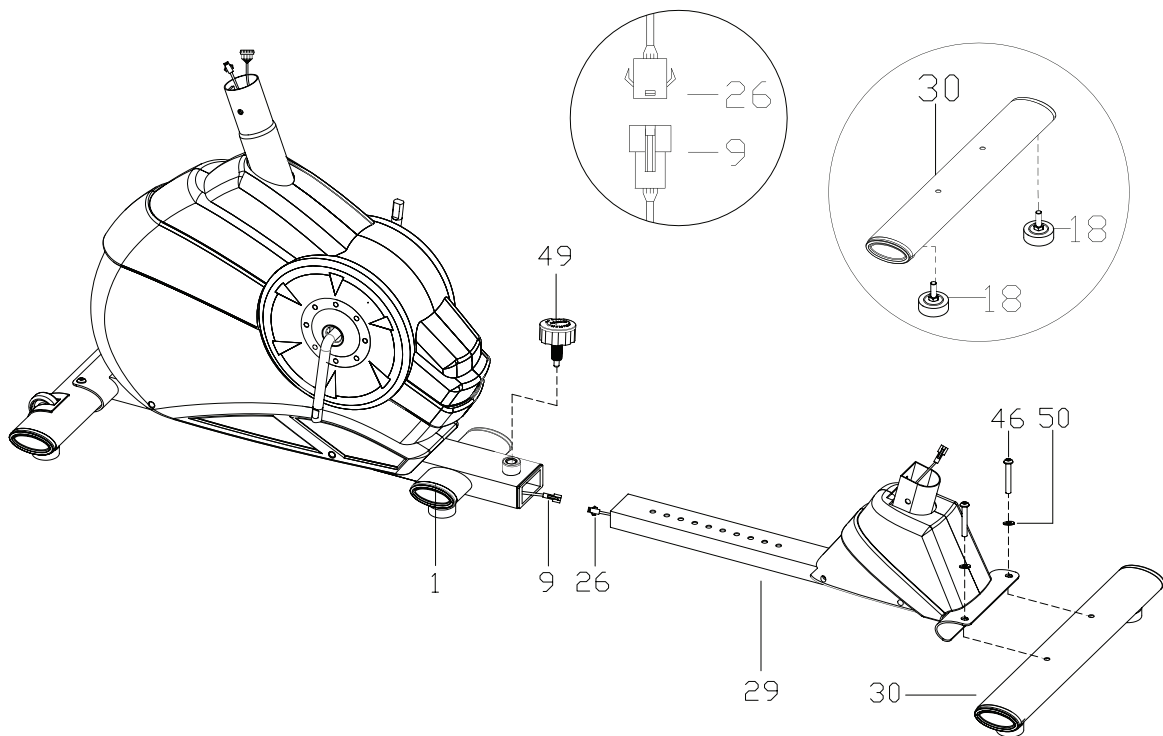
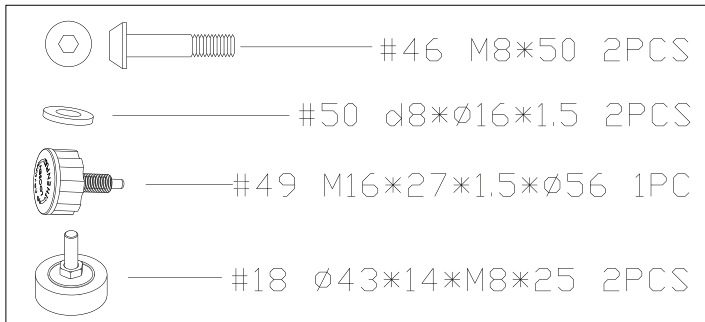



## STEP 4

Put seat support Tube Joint (42) through Tube Protector Cover (52), connect Wire 3 (26) and Wire 4 (41). Slide seat support Tube Joint (42) into extension Tube Joint (29). Attach support Tube Joint (42) to the extension Tube Joint (29) with Screw (45) and Washer (50). Cover up with Tube Protector Cover (52).

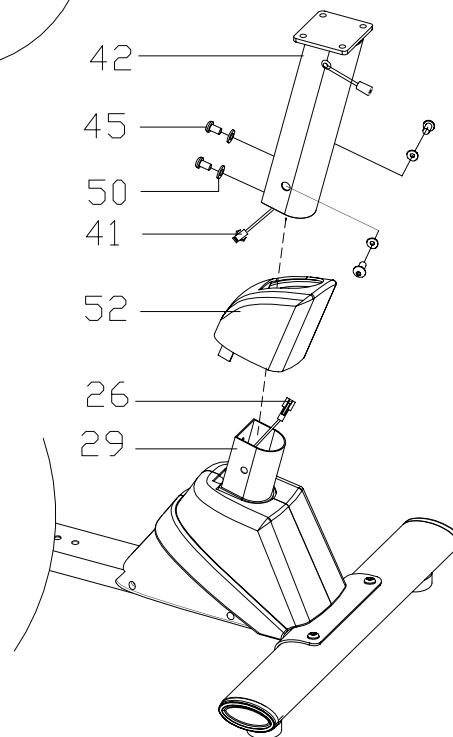
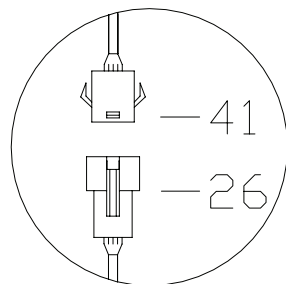
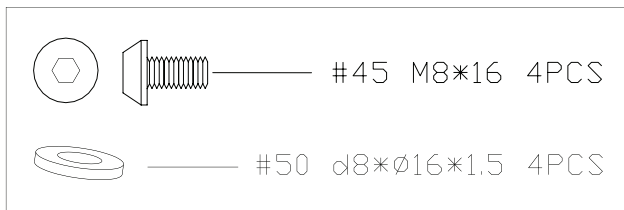

## STEP 5

Attach Seat Post (31) to seat support Tube Joint (42) with Screw (45), Spring (47) and Washer (50). Attach Cushion (33) to Seat Post (31) with Screw (45) and Washer (50). Attach Back Cushion (34) to Seat Post (31) with Screw (12) and Washer (11).

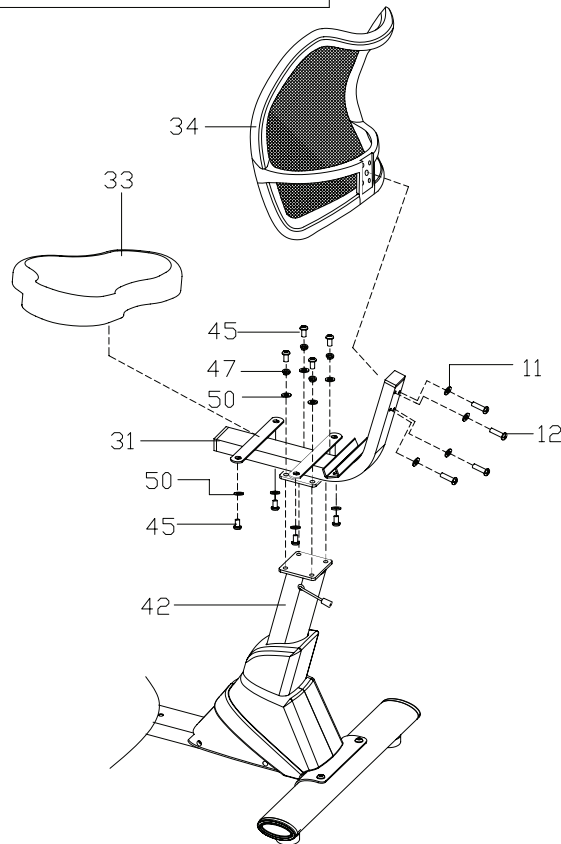
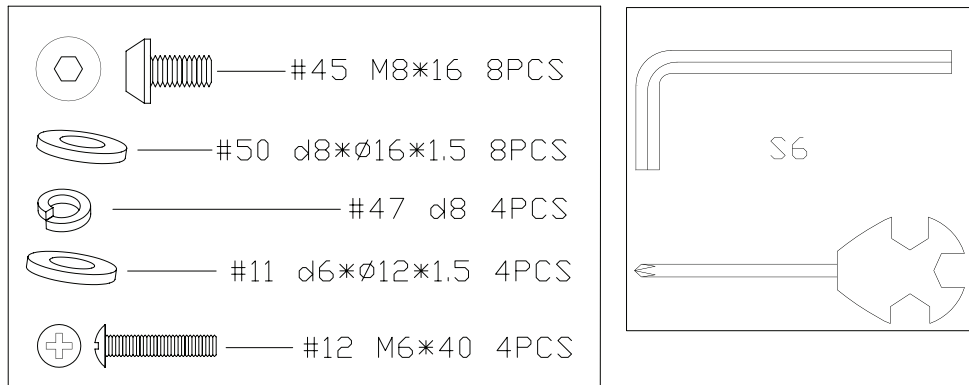

## STEP 6

Lock Handlebar Joint (23) and Handlebar Cover (40) on Seat Post (31) with Bolt (51), Nut (48) and Washer (50). Connect Wire (41) with Wire (39).

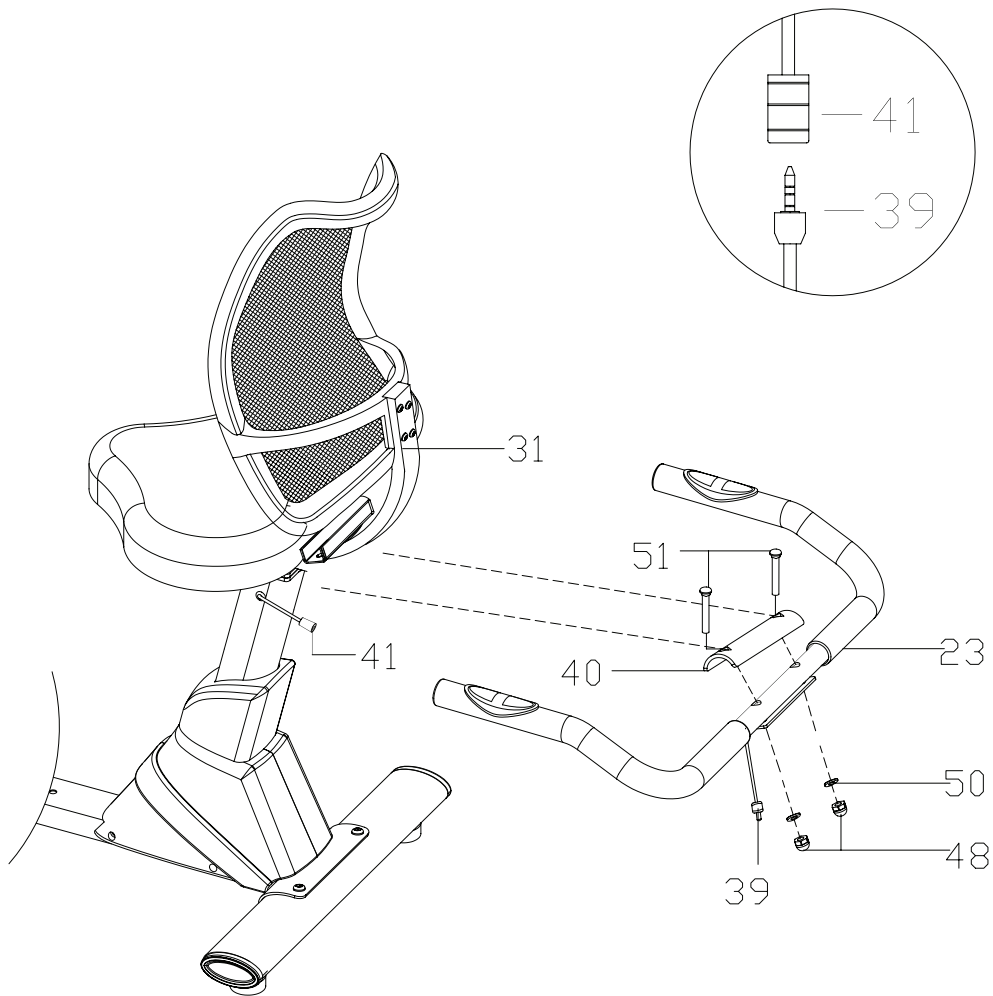
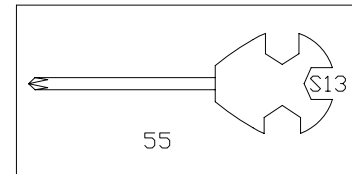
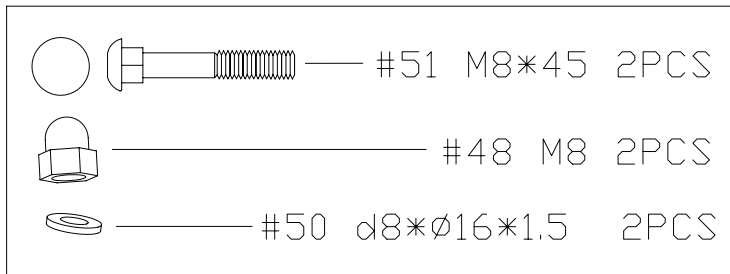

## STEP 7

Thread Pedals (14L\R) on Main Frame (1). Note the thread direction.

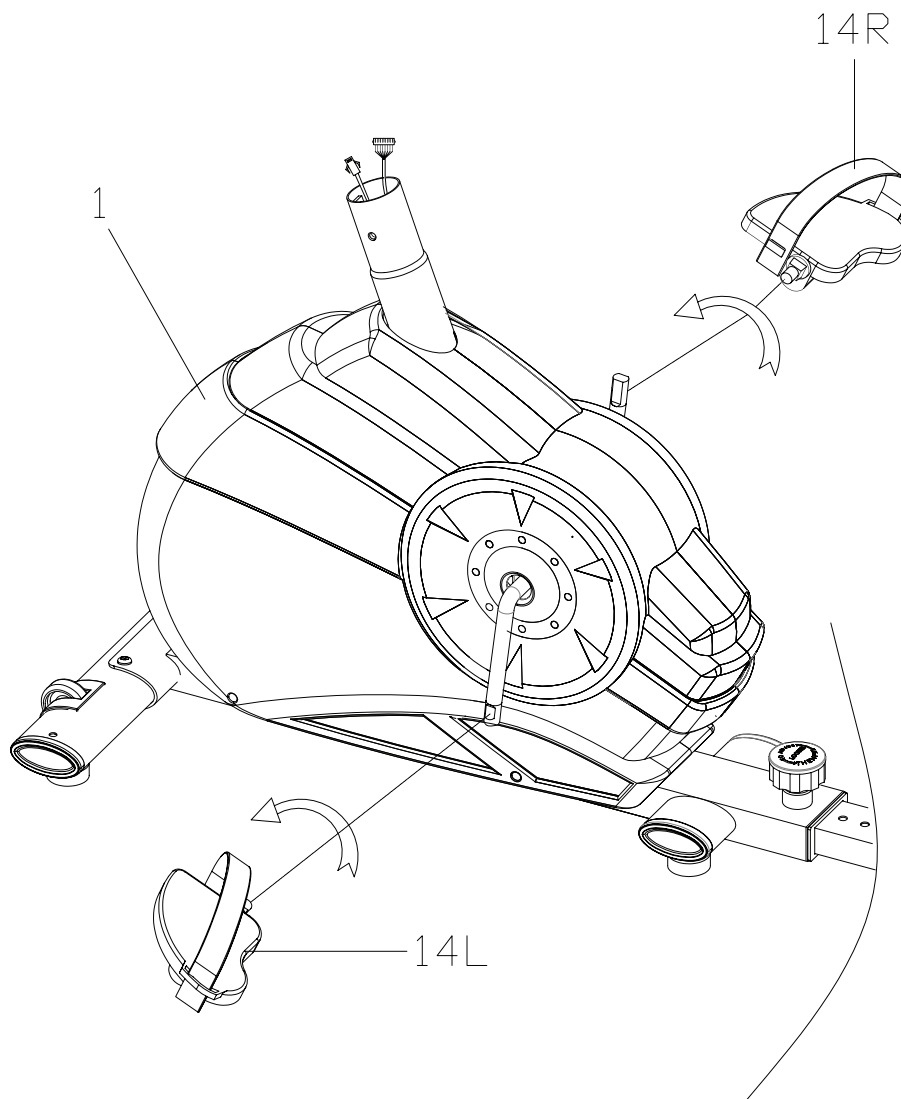
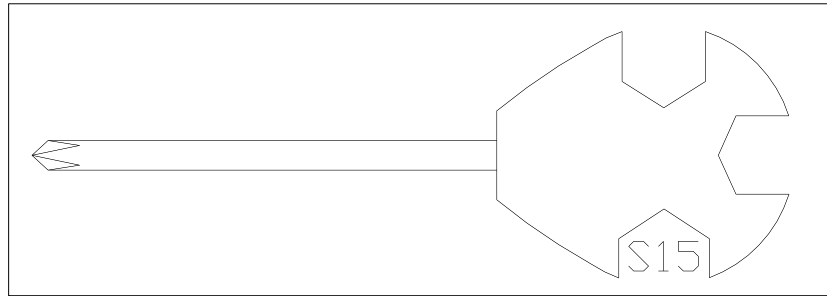

## STEP 8

Connect Pulse Wire (4) with Wire (9) connect Wire (5) and Wire (10). Lock Handlebar Post Joint (8) on Main Frame (1) with Bolt (45) and Washer (44). Lock front Armrest Joint (15) on Handlebar Post Joint (8) with Bolt (45) and Washer (44).

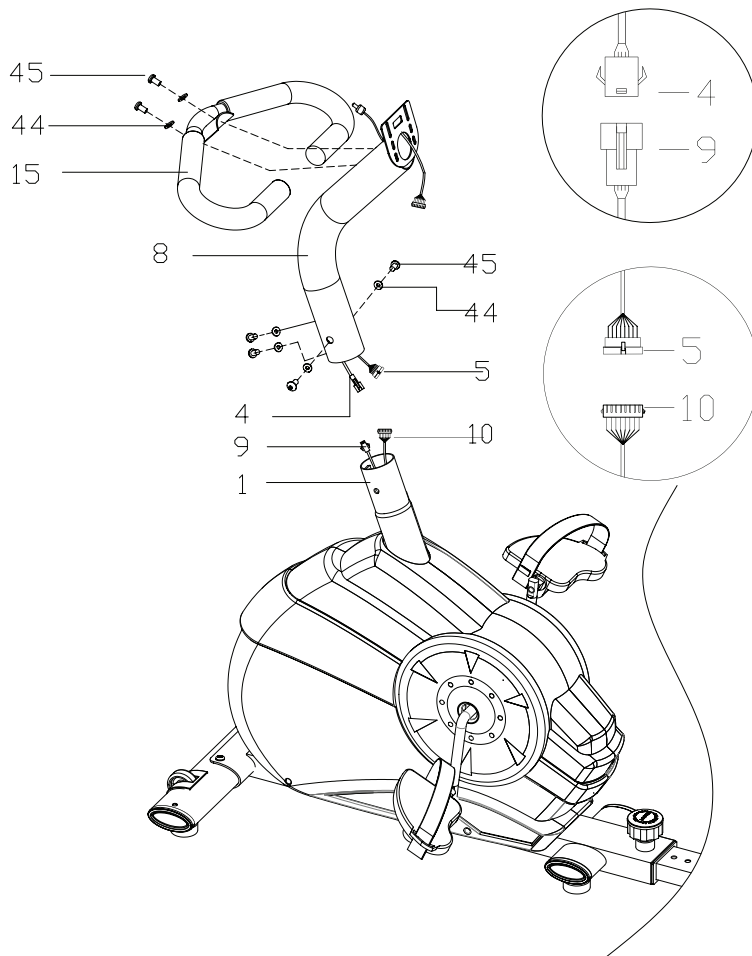
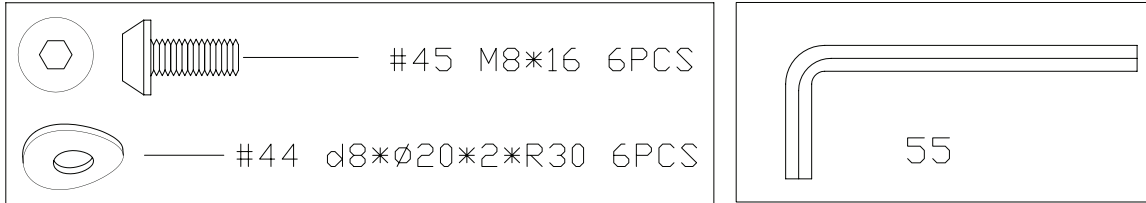

## STEP 9

Connect Wire (5) and Meter Wire (3). Lock Computer (2) on Handlebar Post Joint (8) with Screw (43). Insert Pulse Wire (4) into the back hole of the Computer (2) installation is completed.

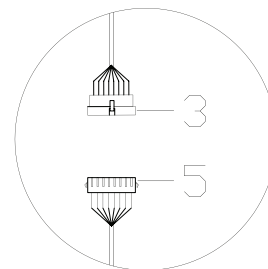
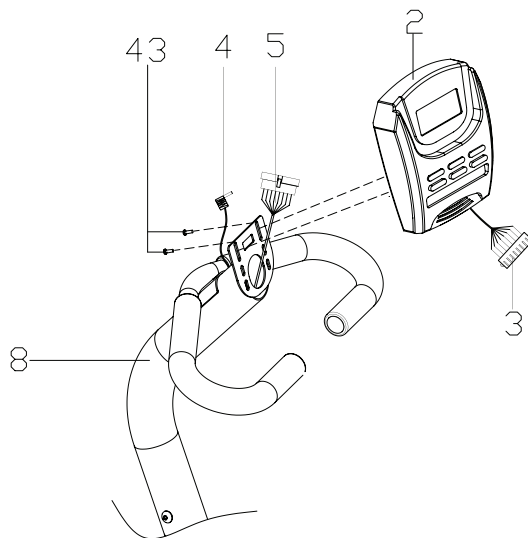
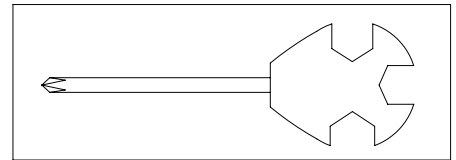

## CONSOLE OPERATIONS

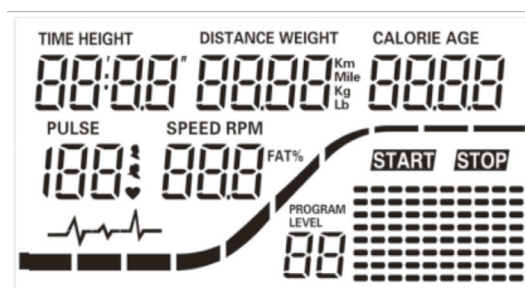

### THE THINGS YOU SHOULD KNOW BEFORE EXERCISE:

#### A. Input Power

Plug in the adaptor to the bike and then the computer will produce a beep sound. The computer will start at the Manual mode.

#### B. Program select and setting value

1. Use the UP or DOWN keys to select program mode and then press ENTER to confirm the exercise mode.
2. In the Manual mode, the computer will use the UP or DOWN keys to set up the exercise TIME, DISTANCE, CALORIES, PULSE.
3. Press the START/STOP key to start exercise.
4. When you reach the target, the computer will beep notifying you to stop.
5. If you set up more than one target and you would like to reach next target, press START/STOP key to continue exercising.

#### C. Wake-Up Function

The monitor will enter SLEEP mode (LCD off) when there is no signal input and no key pressed after 4 minutes.

### FUNCTIONS AND FEATURES:

1. TIME: Shows your elapsed workout time in minutes and seconds. The computer will automatically count up from 0:00 to 99:59 in one second intervals. You can also program the computer to count down from a set value by using the UP and DOWN keys. If you continue exercising once the time has reached 0:00, the computer will begin beeping, and reset itself to the original time set, letting you know your workout is done.
2. DISTANCE: Displays the accumulated distance traveled during each workout up to a maximum of 999.0 MPH.
3. RPM: Revolutions per minute.
4. PEED: Displays the workout speed value in miles per hour.

5. CALORIES: The computer will estimate the cumulative calories burned at any given time during your workout.
6. PULSE: The computer displays your pulse rate in beats per minute during your workout.
7. AGE: The computer is age-programmable from 10 to 99 years. If you do not set an age, this function will always default to age 35.
8. TARGET HEART RATE (TARGET PULSE): The heart rate you should maintain is called your Target Heart Rate in beats per minute.
9. PULSE RECOVERY: During the START stage, continue holding the pulse sensors and then press "PULSE RECOVERY" key, time starts counting from 00:60 - 00:59 - - to 00:00. As soon as 00:00 is reached, the computer will show your heart rate recovery status with the grade F1.0 to F6.0.

- 1.0 means OUTSTANDING
- 1.0<F<2.0 means EXCELLENT
- 2.0≤F≤2.9 means GOOD
- 3.0≤F≤3.9 means FAIR
- 4.0≤F≤5.9 means BELOW AVERAGE
- 6.0 means POOR

Note: If no pulse signal input is detected then the computer will show "P" on the PULSE window. If the computer shows "ERR" on the message window, please re-press the PULSE RECOVERY key and please make sure your hands are on the the pulse sensor.

### KEY FUNCTION:

There are 6 button keys and the function description as follows:

1. START/STOP key:
  - Quick Start function: Allows you to start the computer without selecting a program. Manual workout only. Time automatically begins to count up from zero
  - During the exercise mode, press the key to STOP exercise.
  - During the stop mode, press the key to START exercise.
2. UP key:
  - Press the key to increase the resistance during exercise mode.
  - During the setting mode, press the key to increase the value of Time, Distance, Calories, Age and select Gender and Program.



3. DOWN key:

- Press the key to decrease the resistance during exercise mode.
- During the setting mode, press the key to decrease the value of Time, Distance, Calories, Age and select Gender and Program.

4. ENTER key:

- During the setting mode, press this key to accept the current data entry.
- Hold this key for over two seconds to reset all values to zero or default value.
- While setting the Clock, press this key to accept the hour and minute.

5. BODY FAT key: Press the key to input your HEIGHT, WEIGHT, GENDER and AGE then to measure your body fat ratio,

6. PULSE RECOVERY key: Press the key to activate heart rate recovery function.

## **PROGRAM INTRODUCTION & OPERATION:**

### **Manual Program: Manual**

P1 is a manual program. User can start exercise by pressing START/STOP key. The default resistance level is 5. Users may exercise in any desired of resistance level (Adjusting by UP/DOWN keys during the workout) with a period of time or a number of calories or a certain distance. Operations:

1. Use UP/DOWN keys to select the MANUAL (P1) program.
2. Press the ENTER key to enter MANUAL program.
3. The TIME will flash and you can press UP or DOWN keys to set your exercise TIME. Press ENTER key to confirm your desired TIME.
4. The DISTANCE will flash and you can press UP or DOWN keys to set your target DISTANCE. Press ENTER key to confirm your desired DISTANCE.
5. The CALORIES will flash and you can press UP or DOWN keys to set your exercise CALORIES. Press ENTER key to confirm your desired CALORIES.
6. The PULSE will flash and then you can press UP or DOWN keys to set your exercise PULSE. Press ENTER key to confirm your desired Pulse.
7. Press the START/STOP key to begin exercise.

### **Preset Program: Steps, Hill, Rolling, Valley, Fat Burn, Ramp, Mountain, Intervals, Random, Plateau, Speedplay, Precipice Program**

PROGRAM 2 to PROGRAM 13 are the preset programs. Users may exercise in any desired of resistance level (Adjusting by UP/DOWN keys during the workout) with a period of time or a number of calories or a certain distance. Operations:

1. Use UP/DOWN keys to select one of the above programs from P2 to P13.

2. Press the ENTER key to enter your workout program.
3. The TIME will flash and you can press UP or DOWN keys to set your exercise TIME. Press ENTER key to confirm your desired TIME.
4. The DISTANCE will flash and you can press UP or DOWN keys to set your target DISTANCE. Press ENTER key to confirm your desired DISTANCE.
- 5 The CALORIES will flash and you can press UP or DOWN keys to set your exercise CALORIES. Press ENTER key to confirm your desired CALORIES.
6. The PULSE will flash and then you can press UP or DOWN keys to set your exercise PULSE. Press ENTER key to confirm your desired Pulse.
7. Press the START/STOP key to begin exercise.

### **User Setting Program: User 1, User 2, User 3, User 4**

Program 14 to 17 are the user setting programs. Users are free to create the values in the order of TIME, DISTANCE, CALORIES and the resistance level in 10 columns. The values and profiles will be stored in the memory after setup. Operations:

1. Use UP/DOWN keys to select the USER program from P14 to P17.
2. Press the ENTER key to enter your workout program.
3. The column 1 will flash, and then use the UP/DOWN keys to create your personal exercise profile. Press ENTER to confirm your first column of exercise profile. The default level is load 1.
4. The column 2 will flash, and then use the UP/DOWN keys to create your personal exercise profile. Press ENTER to confirm your second column of exercise profile.
5. Follow the above description 5 and 6 to finish your personal exercise profiles. Press ENTER to confirm your desired exercise profile.
6. The TIME will flash and you can press UP or DOWN keys to setting your exercise TIME. Press ENTER key to confirm your desired TIME.
7. The DISTANCE will flash and you can press UP or DOWN keys to setting your target DISTANCE. Press ENTER key to confirm your desired DISTANCE.
8. The CALORIES will flash and you can press UP or DOWN keys to setting your exercise CALORIES. Press ENTER key to confirm your desired CALORIES.
9. The PULSE will flash and then you can press UP or DOWN keys to set your exercise PULSE. Press ENTER key to confirm your desired Pulse.
10. Press the START/STOP key to begin exercise.

### **Heart Rate Control Program: 55% H.R.C., 65% H.R.C., 75% H.R.C., 85% H.R.C., Target H.R.C.**

Program 18 to Program 22 are the Heart Rate Control Programs and Program 22 is the Target Heart Rate Control program.

Program 18 is the 55% Max H.R.C. - - Target H.R. =  $(220 - \text{AGE}) \times 55\%$

Program 19 is the 65% Max H.R.C. - - Target H.R. =  $(220 - \text{AGE}) \times 65\%$

Program 20 is the 75% Max H.R.C. - - Target H.R. =  $(220 - \text{AGE}) \times 75\%$

Program 21 is the 85% Max H.R.C. - - Target H.R. =  $(220 - \text{AGE}) \times 85\%$

Program 22 is the Target H.R.C. - - Workout by your target heart rate value.

Users can exercise according to your desired Heart Rate program by setting your AGE, TIME, DISTANCE, CALORIES or TARGET PULSE. In these programs, the computer will adjust the resistance level according to the heart rate detected. For example, the resistance level may increase every 20 seconds while the heart rate detected is lower than the TARGET H.R.C. Also the resistance level may decrease every 20 seconds while the heart rate detected is higher than the TARGET H.R.C. Operations:

1. Use UP/DOWN keys to select one of the heart rate control program from P18 to P22.
2. Press the ENTER key to enter your workout program
3. The AGE will flash at P18 to P21 programs and you can press UP or DOWN keys to set your AGE. The default age is 35.
4. At program 22, the TARGET PULSE will flash and you can press UP or DOWN keys to set your TARGET PULSE between 80 to 180. The default TARGET PULSE is 120.
5. The TIME will flash and you can press UP or DOWN keys to set your exercise TIME. Press ENTER key to confirm your desired TIME.
6. The DISTANCE will flash and you can press UP or DOWN keys to set your target DISTANCE. Press ENTER key to confirm your desired DISTANCE.
7. The CALORIES will flash and you can press UP or DOWN keys to set your exercise CALORIES. Press ENTER key to confirm your desired CALORIES.
8. Press the START/STOP key to begin exercise.

### **Body Fat Program: Body Fat**

Program 23 is a special program designed to calculate users' body fat ratio and to offer a specific loading profile for users. There are 3 body types divided according to the FAT% calculated.

Type1: BODY FAT% > 27

Type2:  $27 \geq \text{BODY FAT}\% \geq 20$

Type3: BODY FAT % < 20

The computer will show the test results of FAT PERCENT, BMI and BMR. Operations:

1. Use UP/DOWN keys to select the BODY FAT (P24) program.
2. Press the ENTER key to enter your workout program.
3. The HEIGHT will flash and you can press UP or DOWN keys to set your HEIGHT. Press ENTER key to confirm your HEIGHT. The default HEIGHT is 170cm or 5'07"

(5feet 7 inches).

4. The WEIGHT will flash and you can press UP or DOWN keys to set your WEIGHT. Press ENTER key to confirm your WEIGHT. The default WEIGHT is 70kgs or 155lbs.

5. The GENDER will flash and you can press UP or DOWN keys to select your sex. Number 1 equals male and "zero" means female. Press ENTER key to confirm your Gender. The default sex is 1 (MALE).

6. The AGE will flash and you can press UP or DOWN keys to set your AGE. Press ENTER key to confirm your AGE. The default AGE is 35.

7. Press the START/STOP key to begin body fat measurement. If the window show E on the window, please make sure your hands are on the pulse sensor. Then press the START/STOP key again to begin body fat measurement.

8. After your measurement is completed, the computer will show the values of BMR, BMI and FAT PERCENT on the LCD display. Furthermore, the computer will show your own exercise profile for your body type.

9. Press START/STOP key to begin exercise.

## **OPERATION GUIDE:**

### 1. Sleep Mode:

The computer will enter the sleep mode when there is no signal input and no keys are pressed after 4 minutes. You can press any key to wake up the computer.

2. BMI (Body Mass Index): BMI is a measure of body fat based on height and weight that applies to both adult men and women.

3. BMR (Basal Metabolic Rate): Your Basal Metabolic Rate (BMR) shows the number of calories your body needs to operate. This doesn't account for any activity, it's simply the energy needed to sustain a heartbeat, breathing and normal body temperature. It measures the body at rest, not sleep, at room temperature.

### Error Message:

#### E1 (ERROR 1):

Normal state: During workout, if the monitor does not get signal from the adjustment motor more than 4 seconds and check under successive 3 times then the LCD will show E1.

Power on state: The adjustment motor will return to zero automatically, when the signal of motor cannot be detected for more than 4 seconds then the adjustment motor's driver will be cut off immediately and show the E1 on the LCD display. All the other digital and function mark are blank, and the output signals are cut off also.

E2 (ERROR 2): When the monitor read the memory data, if the I.D. code is not correct or the memory IC is damaged then the monitor will show E2 immediately at power up.

## E3 (ERROR 3): Faulty Motor

Technical data of the current adapter:

Available for Input: 110V/50Hz or 60Hz Output: 6V DC/0.5-1A

### LCD WORKOUT GRAPHICS:

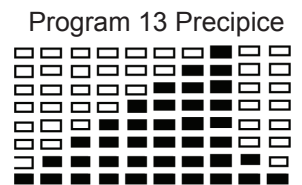
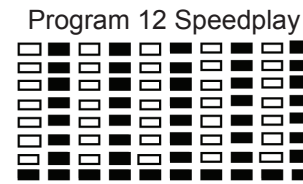
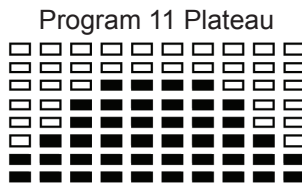
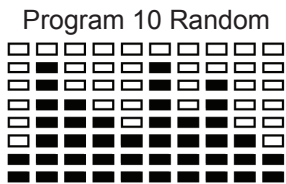
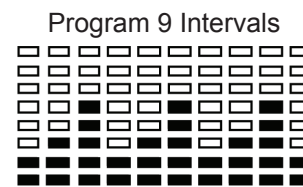
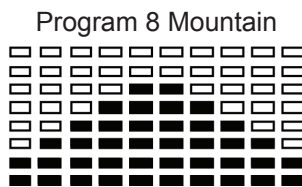
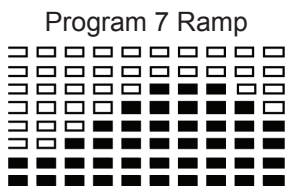
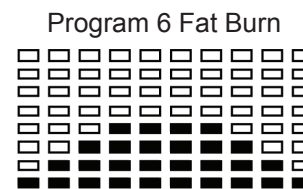
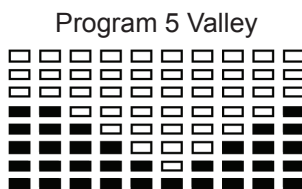
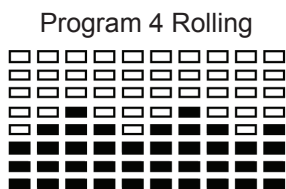
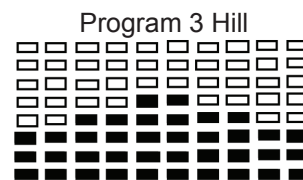
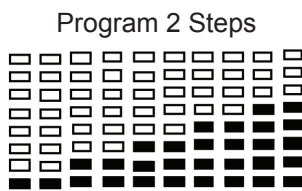
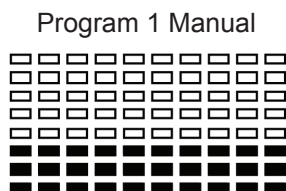

## USER SETTING PROGRAM:

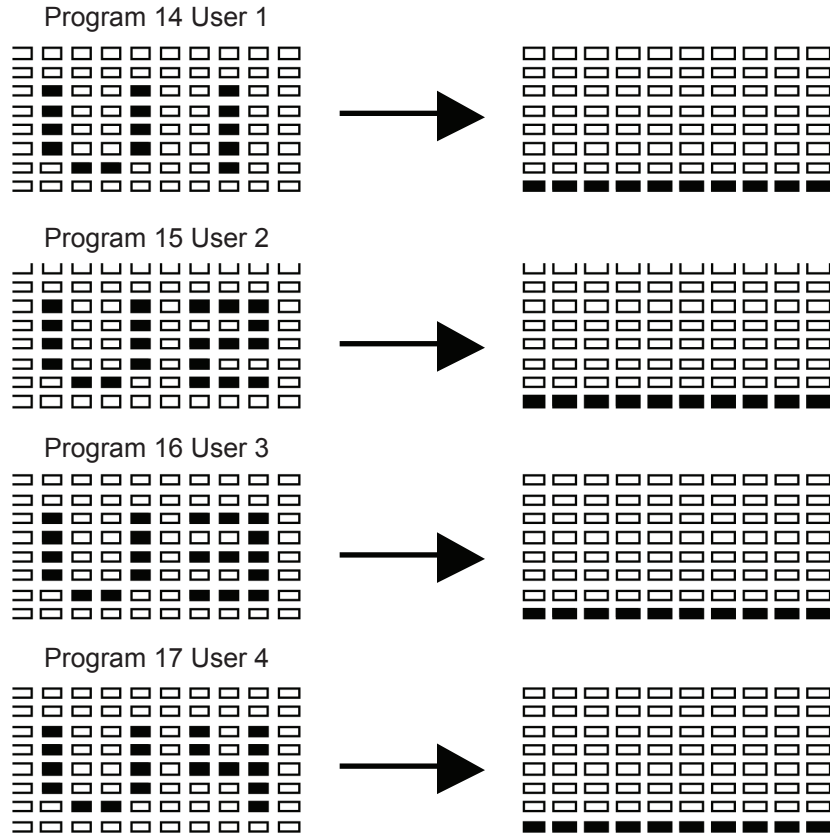

## HEART RATE PROGRAM PROFILES:

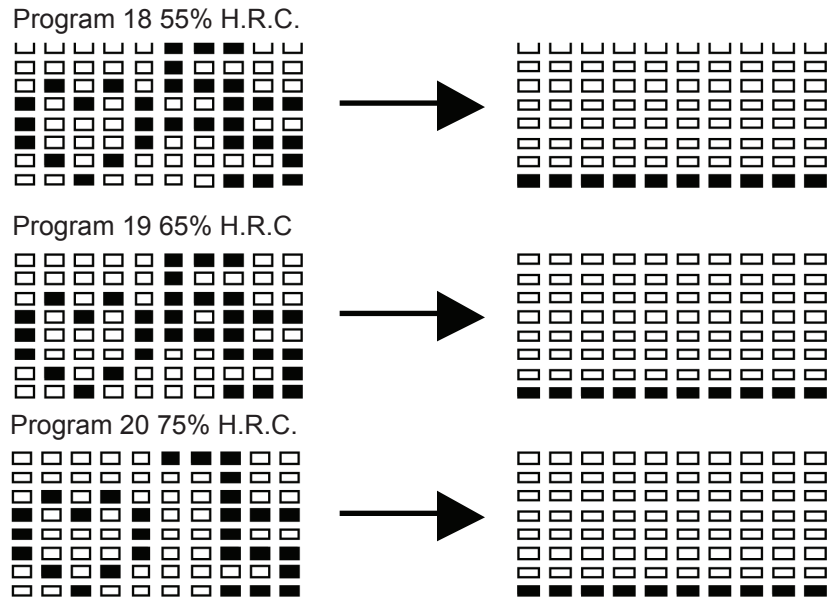

Program 21 85% H.R.C.

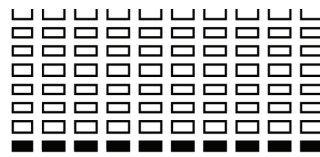
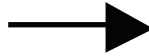
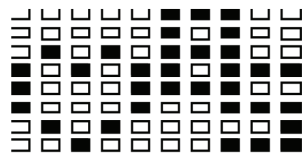

Program 22 85% Target H.R.C.

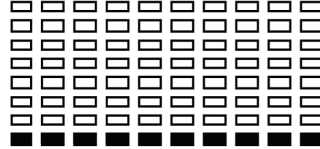
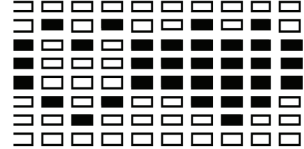

### BODY FAT TEST PROGRAMS:

Program 23

BODY FAT (STOP MODE)

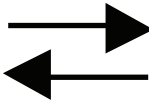
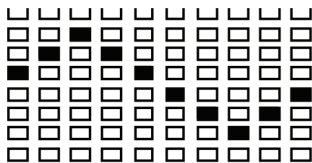

BODY FAT (START MODE)

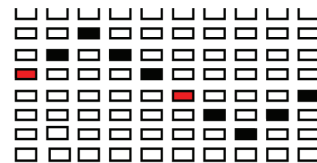

One of the Following Six Profiles Will Display Automatically after Measuring Your BODY FAT:

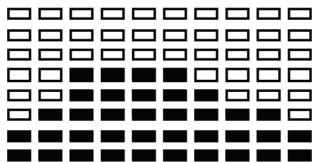

Workout Time: 40 minutes

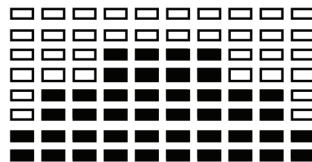

Workout Time: 40 minutes

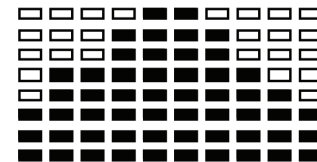

Workout Time: 20 minutes

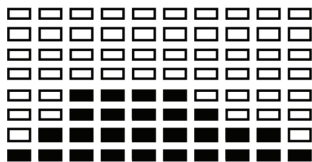

Workout Time: 40 minutes

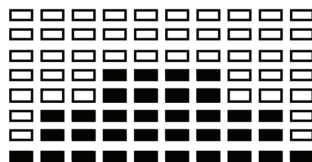

Workout Time: 40 minutes

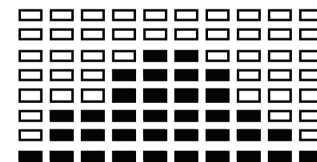

Workout Time: 20 minutes

## MAINTENANCE AND CLEANING

Care has been taken to assure that your recumbent bike has been properly adjusted and lubricated at the factory. It is not recommended that the user attempt service on the internal components. Instead, seek service from an authorized service center. However, you may clean the outer surface. Use a soft cloth, dampened with warm water. Do not use aerosol sprays or pump bottles as they may deposit sediments upon the console surface. The use of harsh chemicals will destroy the protective coating and cause a static build-up that may damage the some of the components.



# EXPLODED VIEW DRAWING

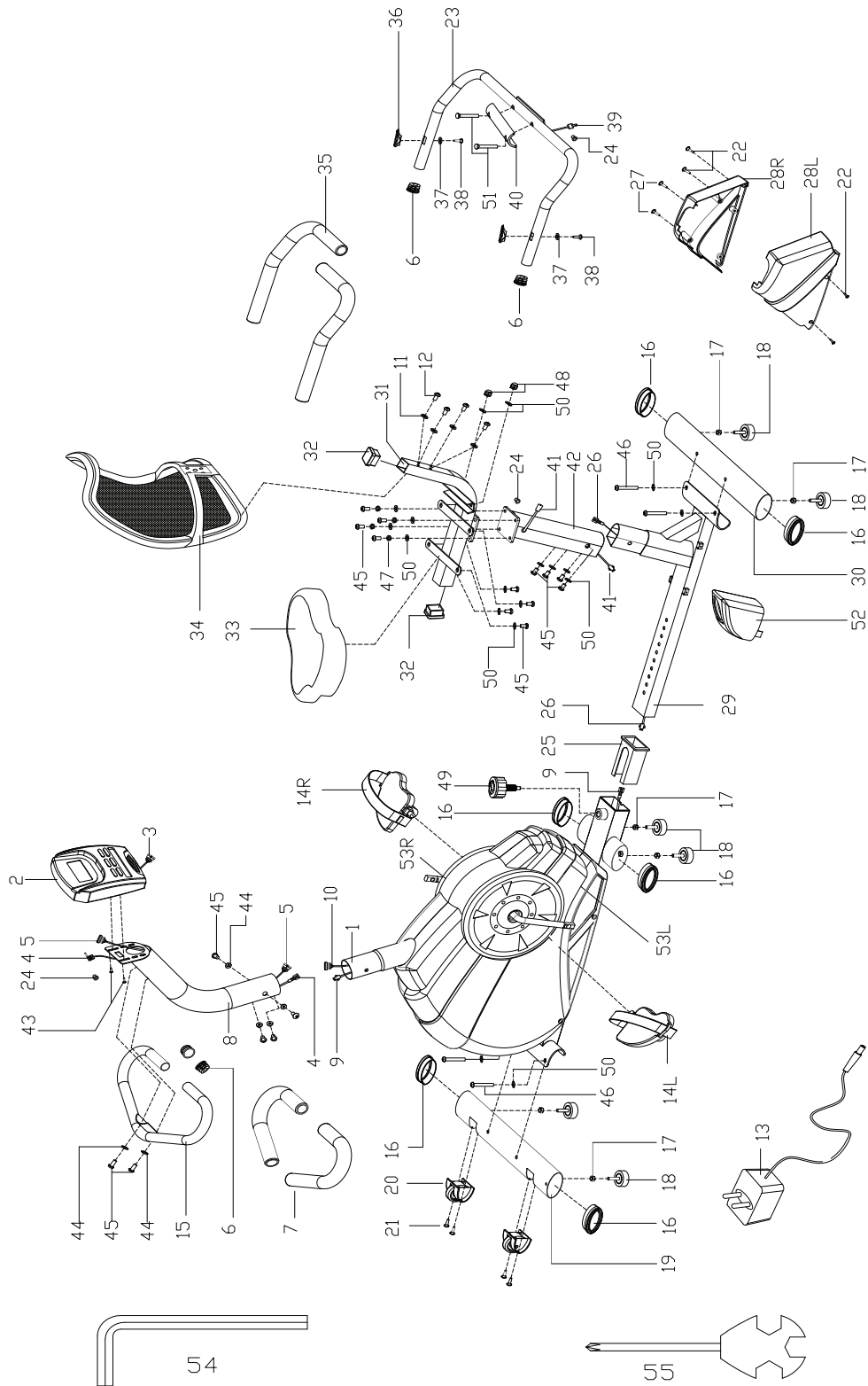

# EXPLODED VIEW DRAWING CONTINUED

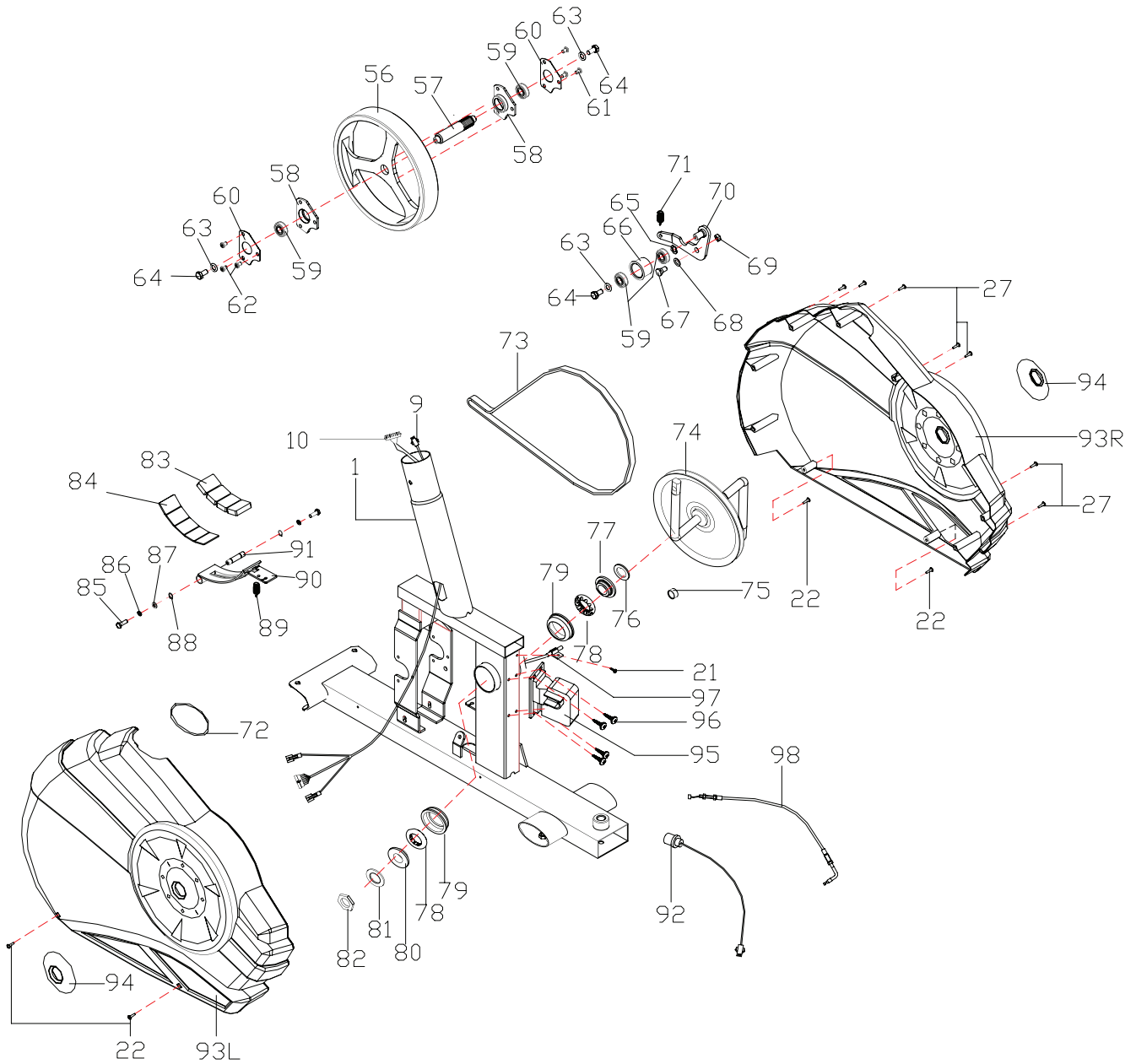

## PARTS LIST

**To order replacement parts: provide your customer service representative with the product model number and the part number located on the Parts List below, along with the quantity you require.**

No	Description	Qty	No	Description	Qty
1	Main frame	1	29	Extension tube joint	1
2	Meter computer	1	30	Back bottom tube	1
3	Meter wire	1	31	Seat post	1
4	Pulse wire 1	1	32	Endcap F38*38	2
5	Wire 1	1	33	Cushion	1
6	Round end cap Φ25*16	4	34	Back cushion	1
7	Foam grip Φ23*5*400	2	35	Foam grip Φ23*5*500	2
8	Handlebar post joint	1	36	Handle pulse	2
9	Wire 2	1	37	Washer d6*Φ12*1.0	2
10	Wire 2	1	38	Screw ST4.2*19	2
11	Washer d6*Φ12*1.5	4	39	Wire	1
12	Screw M6*40	4	40	Handlebar cover	1
13	Transformer	1	41	Wire 4	1
14L/R	Pedal	2	42	Seat support tube joint	1
15	Front armrest joint	1	43	Screw M5*10	2
16	Elliptical endcap PT70*30*33	6	44	Washer d8*Φ20*2*R30	6
17	Nut M8	6	45	Bolt M8*16	18
18	Foot pad Φ43*14*M8*25	6	46	Nut M8*50	4
19	Front bottom tube	1	47	Spring d8	4
20	Rolling shelf	2	48	Nut M8	2
21	Screw ST4.2*16	4	49	Big knob M16*1.5*27*Φ56	1
22	Screw ST4.2*10	8	50	Washer d8*Φ16*1.5	18
23	Handlebar joint	1	51	Bolt M8*43	2
24	Endcap	3	52	Tube protect cover	1
25	Bushing J80*40*J60*30*L201*31	1	53L/R	Chain cover	2
26	Wire 3	1	54	Inner hex spanner S6	1
27	Bolt ST4.2*19	9	55	Spanner S13-14-15	1
28L/R	Small protect cover	2	56	Flywheel 2KG	1
57	Flywheel axle Φ20*103	1	78	Rolling ball	2
58	Bearing	2	79	Nine bowl	2
59	Bearing 6001-2RS	4	80	Nut 2	1
60	Fixed washer t1.5	2	81	Washer	1
61	Screw M6*8	1	82	Nut	1
62	Screw M6*10	5	83	Magnet 40*25*10	4
63	Washer d6*Φ16*1.5	5	84	Magnetic fixation case	1
64	Bolt M6*10	3	85	Bolt M6*16	2
65	Washer d12*Φ15.5*0.3	1	86	Washer d6	2
66	Idler wheel Φ39*24	1	87	Screw d6*Φ12*1.2	2
67	Bolt M8*12*S12	1	88	Washer d12	2
68	Washer d12*Φ15*0.5	1	89	Pull staff Φ1.6*Φ14.5	1
69	Nylon nut M8	1	90	Magnetic force board joint	1
70	Idler wheel connect staff	1	91	Magnetic force board axle	1
71	Pull staff Φ2.5*Φ18*71*N14	1	92	Wire	1
72	Washer	1	93L/R	Chain cover	2
73	Belt	1	94	Cover for the crank	2
74	Crank joint	1	95	Electric motor	1
75	Magnet Φ15*7	1	96	Screw M5*10	4
76	Screw	1	97	Inductor	1
77	Nut 1	1	98	Electric trimming line	1
				Φ=Diameter	

## WARRANTY

### LIMITED RESIDENTIAL WARRANTY

Bladez Fitness will repair or replace, free of charge, at its option, parts that are defective as a result of material or workmanship. Lifetime replacement warranty coverage on frame and one (1) year on other parts. Labor warranty coverage 90 days. Warranty covers the original consumer purchaser only.

### THIS WARRANTY DOES NOT COVER

- Pre-delivery set-up.
- Components that require replacement due to dirt or lack of regular maintenance.
- Expendable items which become worn during normal use.
- Repairs necessary because of operator abuse or negligence or the failure to operate and maintain the equipment according to the instructions contained in the Owner's Manual.

For more detailed warranty information or to register your product warranty easily online, visit our website at: **[www.BladezFitness.com](http://www.BladezFitness.com)**

**FOR WARRANTY REPAIRS, PLEASE DO NOT TAKE YOUR MACHINE  
BACK TO THE RETAIL STORE. CONTACT BLADEZ FITNESS FIRST.**

Bladez Fitness/BH North America Corporation  
20155 Ellipse  
Foothill Ranch, CA 92610  
Phone: 949.206.0330; Toll Free: 866.325.2339; Fax: 949.206.0013  
Web: [www.bladezfitness.com](http://www.bladezfitness.com)  
Mon - Fri 8am - 5pm PST